

White LED Driver with Automatic Dimming Control

■ GENERAL DESCRIPTION

The **NJU6052** is a white LED driver with an automatic dimming control. It contains an output driver, a PWM controller, a luminance sensor control (power supply for sensor & A/D converter), a step-up DC/DC converter, a serial interface, etc.

The output driver ensures a 60mA maximum capability which allows the connection of 12 white LEDs (4 series x 3 parallels). Depending on the ambient light sensed with an external luminance sensor, the PWM controller controls PWM duty in 8 steps preselected out of 64 steps. In addition, the frequency of the DC/DC converter is high so that it permits the use of small, low-profile inductors and capacitors to minimize the footprint in space-conscious applications.

All of these benefits make the **NJU6052** suitable for the battery-powered portable applications such as a cellular phone, a camcorder, PDA, etc.

■ PACKAGE OUTLINE

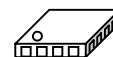

NJU6052KN1

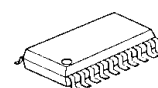

NJU6052V

■ FEATURES

- Drives up to 12 white LEDs (4 series x 3 parallels)
 $V_{SW} = 18.0V(\text{Max.})$, $I_{OUT} = 60mA$
- Built-in PWM Dimming Control
 (Selectable 8 out of 64 steps)
- Built-in Luminance Sensor Control (Power Supply for Sensor & A/D converter)
 (No MPU-access required after initial setting)
- Built-in Temperature Compensation Circuit to Suppress the Characteristic Degradation of LEDs
- Uses Small Inductor and Capacitors
- 1.8V to 3.6V Operating Voltage for Logic Circuits (V_{DDL})
- 3.0V to 5.5V Operating Voltage for Step-up Circuits (V_{DD})
- CMOS Technology
- Package : QFN28 / SSOP20

NJU6052

■ QFN20 PIN CONNECTIONS (TOP VIEW)

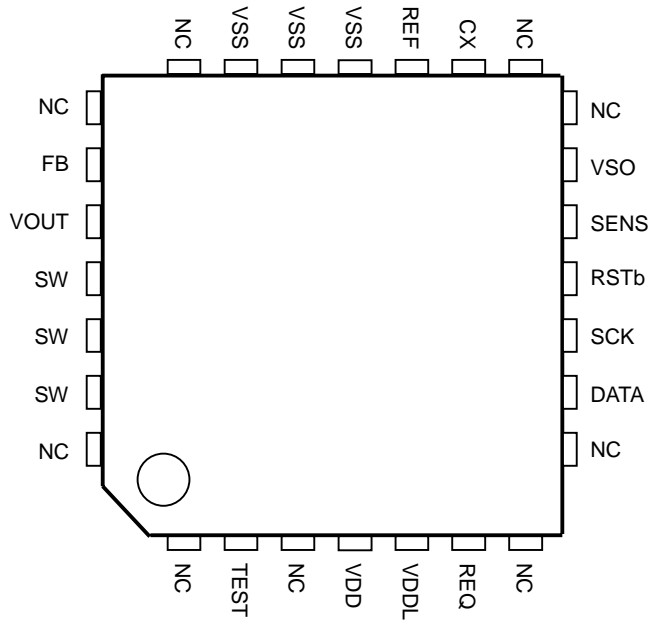

■ SSOP20 PIN CONNECTIONS (TOP VIEW)

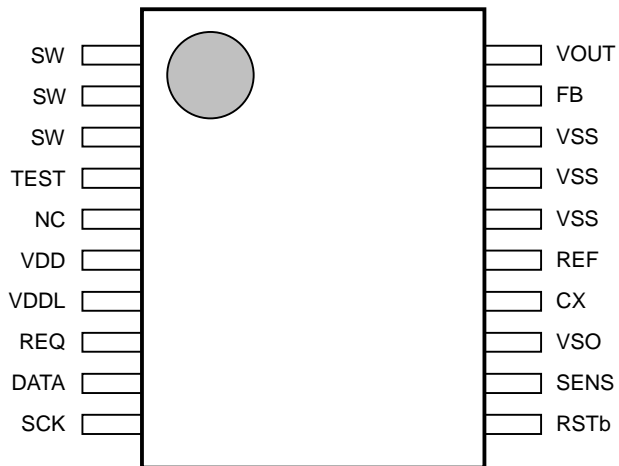

■ PIN DESCRIPTION

No.		SYMBOL	TYPE	DESCRIPTIONS
QFN	SSOP			
4	6	V _{DD}	Power	V_{DD} Power Supply - Power supply for step-up voltage
5	7	V _{DDL}	Power	V_{DDL} Power Supply - Power supply for logic voltage. - Relation: $1.8V \leq V_{DDL} \leq V_{DD}$ should be maintained.
25 26 27	1 2 3	SW	Input	Switch - All these terminals should be connected together.
10	10	SCK	Input	Shift Clock - Serial data is latched on the rising edge of SCK.
9	9	DATA	Input / Output	Serial Data
2	4	TEST	Output	Test - This terminal must be open.
6	8	REQ	Input	Data Request "L" : Writing command data "H" : Reading sensor data
12	12	SENS	Input	Luminance Sensor Connection
11	11	RSTb	Input	Reset - Active "L".
24	20	V _{OUT}	Input	Input - This terminal is connected to LED anode.
23	19	FB	Input	Feedback
18 19 20	16 17 18	V _{SS}	Power	Ground - All these terminals should be connected together.
16	14	CX/TCLK	Input	Oscillator Capacitor Connection / External Clock Input
13	13	V _{SO}	Output	V_{SO} Power Supply - Power supply for luminance sensor - 2.4V typical
17	15	REF	Input	Reference Voltage - This terminal must be open.
1 3 7 8 14 15 21 22 28	5	NC	-	Non Connection - These terminals must be open.

■ BLOCK DIAGRAM

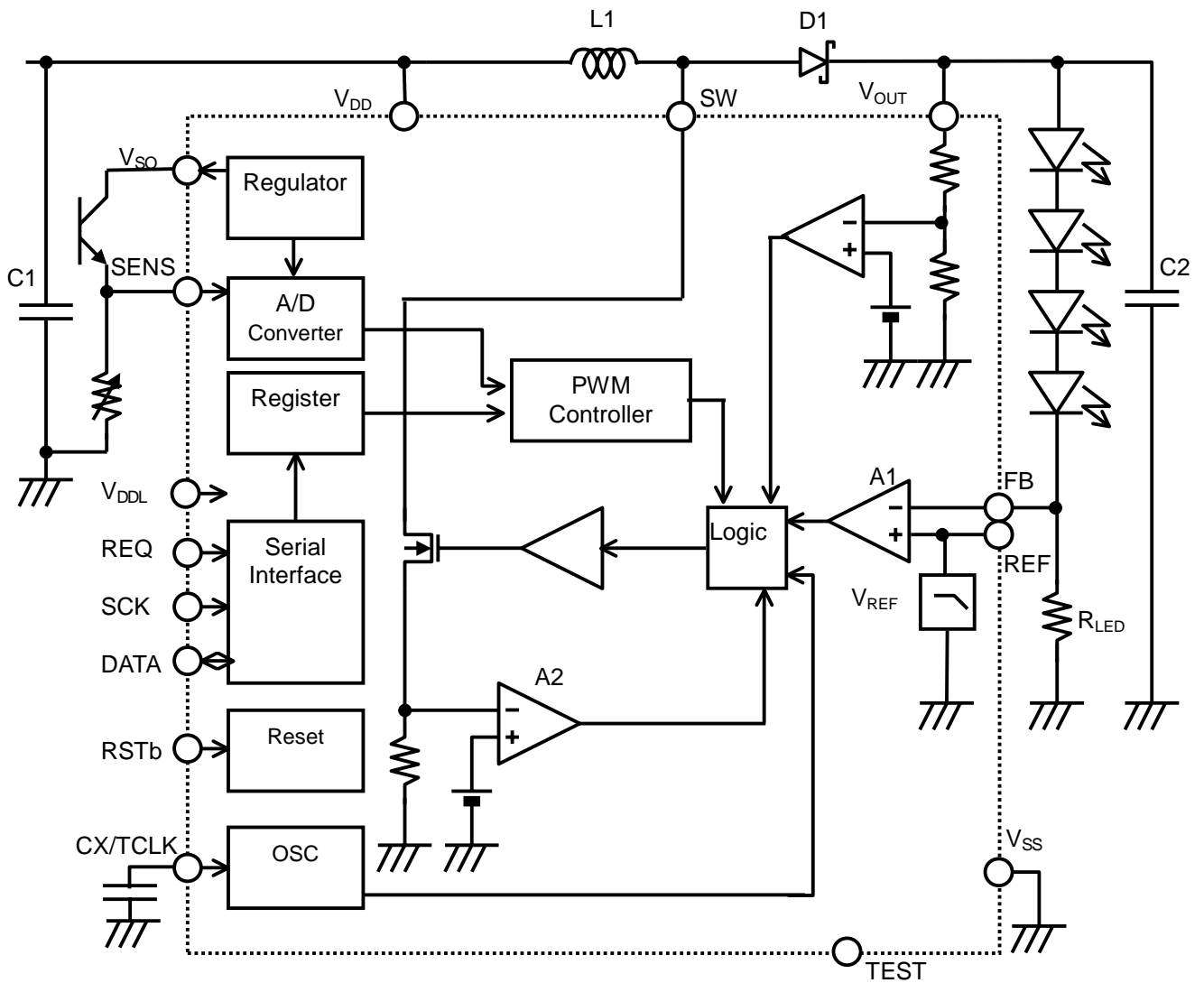

■ FUNCTIONAL DESCRIPTIONS

(1) LED CURRENT CONTROL

The NJU6052 incorporates the LED current control circuit to regulate the LED current (I_{LED}), which is programmed by the feedback resistor (R_{LED}) connected between the FB and V_{SS} terminals. The reference voltage V_{REF} is internally regulated to 0.6V typical and connected to the positive input of the built-in comparator A1. Formula (1) is used to choose the value of the R_{LED} , as shown below.

$$R_{LED} = \frac{V_{REF}}{I_{LED}} \quad \text{--- Formula (1)}$$

$$V_{REF} = 0.6V \text{ (TYP.)}$$

Referring to the block diagram is recommended for understanding the operation of the LED current control. The I_{LED} is the constant current programmed by the R_{LED} . When the feedback voltage on the FB terminal reaches above the reference voltage V_{REF} on the REF terminal (i.e., I_{LED} is above the level programmed by R_{LED}), the output capacitor C2 delivers the I_{LED} . Once the feedback voltage drops below the reference voltage (i.e., I_{LED} drops below the level programmed by R_{LED}), the comparator A1 detects it and turns on the internal MOS switch, then the current of the inductor L1 begins increasing. When this switch current reaches 720mA and the comparator A2 detects it, or when the predetermined switch-on-period expires, the MOS switch is turned off. The L1 then delivers current to the output through the diode D1 as the inductor current drops. After that, the MOS switch is turned on again and the switch current increases up to 720mA. This switching cycle continues until the I_{LED} reaches the level programmed by the R_{LED} , then the I_{LED} is maintained constant.

When the feedback voltage is less than $1/2 * V_{REF}$, the current limit of the MOS switch is reduced to 500mA typical. This action reduces the average inductor-current, minimizes the power dissipation and protects the IC against high current at start-up.

The total forward-voltage of the LEDs must be greater than the power supply voltage V_{DD} , otherwise the LEDs remain lighting up, being out of control.

(2) OSCILLATOR

The built-in oscillator incorporates a reference power supply, so its frequency is independent from the V_{DD} . The frequency is varied by the external capacitor CX, as shown in Figure 7.

(3) LUMINANCE SENSOR CONTROL

The luminance sensor control circuits consist of the power supply for sensor and the A/D converter. The A/D converter senses the voltage on the SENS terminal and selects 1 out of 8 registers (PWM REGISTER 0–7). And the data in the selected register is reflected to the PWM duty (PWM dimming control). The contents of the registers can be programmed through the serial interface, in other words, the dimming control is user-settable.

The voltage sense and the register selection are updated at regular intervals, and the interval period is set by the “DIVIDE” bits. The selected register is held by setting “1” at the “HOLD” bit of the command data.

(4) PWM DIMMING CONTROL

By setting the duty data at “PWM REGISTER” bits, 8 out of 64 registers are assigned to the PWM REGISTER 0-7. The PWM duty is changed depending on the register selected by the SENS voltage. The relation between the PWM REGISTER and its duty is shown below.

TABLE 1 PWM DUTY vs. PWM REGISTER

REGISTER	DUTY	REGISTER	DUTY	REGISTER	DUTY	REGISTER	DUTY
0,0,0,0,0,0	OFF	0,1,0,0,0,0	26.56%	1,0,0,0,0,0	51.56%	1,1,0,0,0,0	76.56%
0,0,0,0,0,1	3.13%	0,1,0,0,0,1	28.13%	1,0,0,0,0,1	53.13%	1,1,0,0,0,1	78.13%
0,0,0,0,1,0	4.69%	0,1,0,0,1,0	29.69%	1,0,0,0,1,0	54.69%	1,1,0,0,1,0	79.69%
0,0,0,0,1,1	6.25%	0,1,0,0,1,1	31.25%	1,0,0,0,1,1	56.25%	1,1,0,0,1,1	81.25%
0,0,0,1,0,0	7.81%	0,1,0,1,0,0	32.81%	1,0,0,1,0,0	57.81%	1,1,0,1,0,0	82.81%
0,0,0,1,0,1	9.38%	0,1,0,1,0,1	34.38%	1,0,0,1,0,1	59.38%	1,1,0,1,0,1	84.38%
0,0,0,1,1,0	10.94%	0,1,0,1,1,0	35.94%	1,0,0,1,1,0	60.94%	1,1,0,1,1,0	85.94%
0,0,0,1,1,1	12.50%	0,1,0,1,1,1	37.50%	1,0,0,1,1,1	62.50%	1,1,0,1,1,1	87.50%
0,0,1,0,0,0	14.06%	0,1,1,0,0,0	39.06%	1,0,1,0,0,0	64.06%	1,1,1,0,0,0	89.06%
0,0,1,0,0,1	15.63%	0,1,1,0,0,1	40.63%	1,0,1,0,0,1	65.63%	1,1,1,0,0,1	90.63%
0,0,1,0,1,0	17.19%	0,1,1,0,1,0	42.19%	1,0,1,0,1,0	67.19%	1,1,1,0,1,0	92.19%
0,0,1,0,1,1	18.75%	0,1,1,0,1,1	43.75%	1,0,1,0,1,1	68.75%	1,1,1,0,1,1	93.75%
0,0,1,1,0,0	20.31%	0,1,1,1,0,0	45.31%	1,0,1,1,0,0	70.31%	1,1,1,1,0,0	95.31%
0,0,1,1,0,1	21.88%	0,1,1,1,0,1	46.88%	1,0,1,1,0,1	71.88%	1,1,1,1,0,1	96.88%
0,0,1,1,1,0	23.44%	0,1,1,1,1,0	48.44%	1,0,1,1,1,0	73.44%	1,1,1,1,1,0	98.44%
0,0,1,1,1,1	25.00%	0,1,1,1,1,1	50.00%	1,0,1,1,1,1	75.00%	1,1,1,1,1,1	100.00%

The relation between the PWM REGISTER and SENS voltage is reversed by the “REV” bit, as follows.

TABLE 2 REV vs. PWM REGISTER

REV	PWM REGISTER
0	PWM REGISTER0
	PWM REGISTER1
	PWM REGISTER2
	PWM REGISTER3
	PWM REGISTER4
	PWM REGISTER5
	PWM REGISTER6
	PWM REGISTER7
1	PWM REGISTER7
	PWM REGISTER6
	PWM REGISTER5
	PWM REGISTER4
	PWM REGISTER3
	PWM REGISTER2
	PWM REGISTER1
	PWM REGISTER0

Note 1) For the information on the relation between PWM duty and LED current (I_{LED}), refer to “(9-1) PWM DUTY and LED CURRENT”.

Note 2) For the information on the relation between SENS voltage and PWM REGISTER, refer to “DC ELECTRICAL CHARACTERISTICS”.

(5) SERIAL INTERFACE

(5-1) SERIAL DATA WRITE

The serial data is latched into the shift register on the rising edge of the serial clock (SCK), and determined on the rising edge of the data request (REQ). The serial data format should be the MSB first.

For COMMAND data transmission, the command data 1 (CMD1) and the command data 2 (CMD2) should be continuous. The CMD1 is first, then the CMD2. If only 1-byte data is transferred, this data is recognized as the CMD1. Do not transmit 3 bytes or more, because 3rd data is used only for maker test and the 4th and later are ignored. If it's absolute necessary to send the 3 bytes or more in the user's application, the only data (0,0,0,0,0,0,0,0) as the 3rd data can be accepted.

For DUTY data transmission, 8 bytes for PWM REGISTER 0-7 should be continuous. The order is : PWM REGISTER 0, 1, 2, 3, 4, 5, 6 and 7. If 7bytes or less are transferred, all bytes are accepted. And if 9 bytes or more, the 9th and later are ignored.

Note that the data should be in 8*n bits (n=integer number), otherwise it may cause malfunctions. And the SCK should be "0" when the REQ is changed.

SERIAL DATA FORMAT

TABLE 3-1 Command Data 1

B7	B6	B5	B4	B3	B2	B1	B0
0	SOFF	BRIGHT			STBY	HOLD	REV

TABLE 3-2 Command Data 2

B7	B6	B5	B4	B3	B2	B1	B0
0	0	0	0	0	0	DIVIDE	

TABLE 3-3 Duty Data

B7	B6	B5	B4	B3	B2	B1	B0
1	*	PWM REGISTER					

FIGURE 1 COMMAND DATA TRANSMISSION

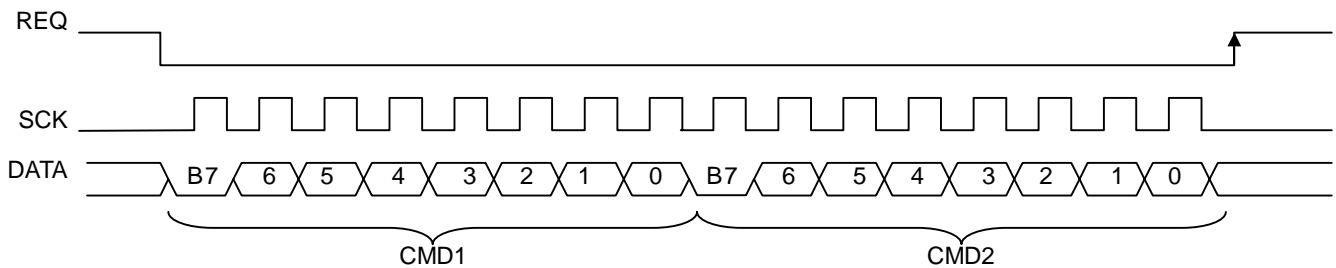
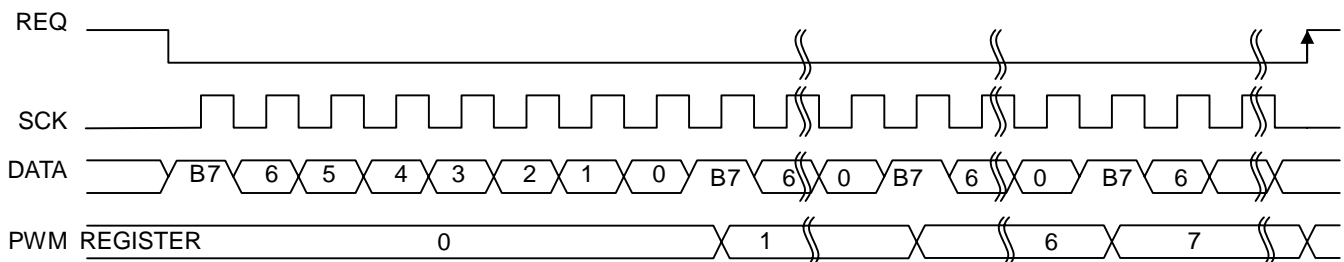

FIGURE 2 DUTY DATA TRANSMISSION



(5-2) SENSOR DATA READ

The DATA terminal becomes output state by setting the REQ terminal to “1” after the command data transmission. And the sensor data is read out, synchronizing with the SCK. The bit number corresponding to a selected register is “1” and the others are “0”, as shown below.

FIGURE 3 SENSOR DATA READ (REV=0, PWM REGISTER4 selected)

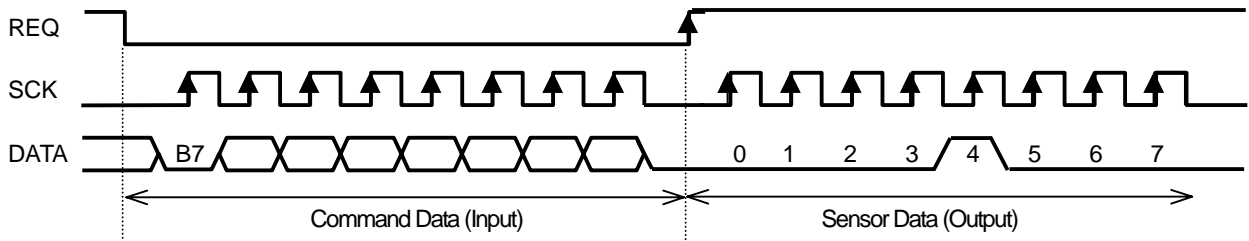

(5-3) SOFF and BRIGHT

By setting “1” at the SOFF bit, the luminance sensor control is disabled and the PWM duty is controlled by the BRIGHT bits, as shown below.

TABLE 4 SOFF and BRIGHT

SOFF	BRIGHT	REV	PWM REGISTER
0	-	0	PWM REGISTER0
			PWM REGISTER1
			PWM REGISTER2
			PWM REGISTER3
			PWM REGISTER4
			PWM REGISTER5
			PWM REGISTER6
			PWM REGISTER7
1	000	-	PWM REGISTER0
	001		PWM REGISTER1
	010		PWM REGISTER2
	011		PWM REGISTER3
	100		PWM REGISTER4
	101		PWM REGISTER5
	110		PWM REGISTER6
	111		PWM REGISTER7

Note 1) When SOFF=“0”, luminance sensor control is enabled and PWM REGISTER is selected according to SENS voltage.

Note 2) For the information on the relation between SENS voltage and PWM REGISTER, refer to “DC ELECTRICAL CHARACTERISTICS”.

(5-4) STBY

By setting “1” at the STBY bit, the NJU6052 goes into the standby mode, as follows.

- DC/DC converter, oscillator, reference voltage generator, and power supply for sensor are halted.
- The contents of PWM REGISTER are maintained.
- Luminance sensor control circuit is initialized.

(5-5) HOLD

By setting “1” at the HOLD bit, the selected PWM REGISTER is held and the luminance sensor control cannot be used. In other words, this setting works so that the luminance of the LEDs doesn’t change even if the SENS voltage changes. The selection is initialized to the PWM REGISTER 0 by the reset. And when the standby is released, the selection is initialized to the PWM REGISTER 0 at REV=“0” or the PWM REGISTER 7 at REV=“1”.

(5-6) REV

By setting “1” at the REV bit, the correspondence between the PWM REGISTER and SENS voltage is reversed.

TABLE 5 REV

REV	PWM REGISTER
0	PWM REGISTER0
	PWM REGISTER1
	PWM REGISTER2
	PWM REGISTER3
	PWM REGISTER4
	PWM REGISTER5
	PWM REGISTER6
	PWM REGISTER7
1	PWM REGISTER7
	PWM REGISTER6
	PWM REGISTER5
	PWM REGISTER4
	PWM REGISTER3
	PWM REGISTER2
	PWM REGISTER1
	PWM REGISTER0

(5-7) DIVIDE

By setting the DIVIDE bits, the sensor-sampling-time (t_{SENS}) and PWM frequency (f_{PWM}) are changed. Note that these parameters are varied depending on the oscillation frequency (F_{OSC}). The formula (2) gives the sensor-sampling-time.

$$t_{sens} = \frac{2^{(17+N)}}{f_{osc}} \quad (\text{sec}) \quad \text{--- Formula (2)}$$

TABLE 6 SENSOR SAMPLING TIME

DIVIDE	N	F_{osc}			
		100kHz	200kHz	400kHz	800kHz
00	0	1.311	0.655	0.328	0.164
01	1	2.621	1.311	0.655	0.328
10	2	5.243	2.621	1.311	0.655
11	3	10.486	5.243	2.621	1.311

UNIT : sec

And, the formula (3) gives the PWM frequency.

$$f_{pwm} = \frac{1}{64} \cdot \frac{f_{osc}}{2^{(3+N)}} \quad (Hz) \quad \text{--- Formula (3)}$$

TABLE 7 PWM FREQUENCY

DIVIDE	N	F _{osc}			
		100kHz	200kHz	400kHz	800kHz
00	0	195.3	390.6	781.3	1562.5
01	1	97.7	195.3	390.6	781.3
10	2	48.8	97.7	195.3	390.6
11	3	24.4	48.8	97.7	195.3

UNIT : Hz

NOTE) PWM frequencies written in bold or neighbors are recommended, otherwise it might cause LED flickering.

(6) LEVEL SHIFTER

The level shifter allows the communication with the MPU working at the power supply voltage lower than the V_{DD}. Apply the MPU power-supply-voltage on the V_{DDL} terminal. The voltage range is: 1.8V ≤ V_{DDL} ≤ 3.6V.

(7) RESET

By setting the RSTB pin to “L”, the NJU6052 is initialized into the following default status.

TABLE 8 RESET

REGISTER	DATA	Default status
REV	0	Refer to Table 5
HOLD	0	Sensor sampling is enabled
STBY	0	Standby Off
BRIGHT	000	
SOFF	0	Luminance sensor control is enabled
DIVIDE	00	
PWM REGISTER0-7	000000	PWM duty 0% (LED off)

(8) TEMPERATURE COMPENSATION

The reference voltage (V_{REF}) generator has temperature compensation, which suppresses the characteristic degradation of LEDs at high temperatures. Refer to “I_{LED} vs. Temperature” shown in the “DC Electrical Characteristics”.

(9) APPLICATIONS INFORMATION

(9-1) PWM DUTY and LED CURRENT

The average LED current is programmed with the single resistor R_{LED} and the PWM duty, as shown in Formula (4).

$$I_{LED(avg)} = I_{LED(max)} \cdot \frac{DUTY}{100} \quad \text{--- Formula (4)}$$

$$I_{LED(max)} = \frac{V_{REF}}{R_{LED}}$$

(9-2) INDUCTOR SELECTION

Formula (5) is used to choose an optimum inductor, as shown below:

$$L = \frac{2 \left(\frac{V_{OUT}}{\eta} - V_{IN} \right) \cdot I_{LED}}{I_{LIMIT}^2 \cdot f_{OSC}} \quad \text{--- Formula (5)}$$

η : Power conversion efficiency (= 0.7 to 0.8)

The power supply voltage V_{IN} may fluctuate in battery-powered applications. For this reason, the minimum voltage should be applied to the V_{IN} in Formula (5).

The **NJU6052** has about 200ns of delay time (T_{DELAY}), which is defined as the period from the reach of the current limit 720mA to the MOS-switch-off. The T_{DELAY} may cause an overshoot-inductor-current, which is called the peak current $I_{L,PEAK}$, and calculated by Formula (6). Therefore, it is recommended that an inductor with a rating twice of the $I_{L,PEAK}$ and a low DCR (DC resistance) be used for high efficiency.

$$I_{L,PEAK} = I_{LIMIT} + \left(\frac{V_{IN(max)} - V_{DS}}{L} \right) \cdot T_{DELAY} \quad \text{--- Formula (6)}$$

V_{DS} : Drain-Source voltage of the MOS switch (= $I_{LIMIT} \cdot R_{ON}$)

$V_{IN(MAX)}$: Maximum of V_{IN} Voltage

(9-3) DIODE SELECTION

A Schottky diode with a low forward-voltage-drop and a fast switching-speed is ideal. And the diode must have a rating greater than the output voltage and the output current in the system.

(9-4) CAPACITOR SELECTION

A low ESR (Equivalent Series Resistance) capacitor should be used at the output to minimize output ripples. A multi-layer ceramic capacitor is the best selection for the **NJU6052** application because of not only the low ESR but its small package. A ceramic capacitor as the input decoupling-capacitor is also recommended and should be placed as close to the **NJU6052** as possible.

■ ABSOLUTE MAXIMUM RATINGS

Ta=25°C

PARAMETERS	SYMBOL	CONDITIONS	RATINGS	UNIT	NOTE
V _{DD} Power Supply	V _{DD}		-0.3 to +6	V	
V _{DDL} Power Supply	V _{DDL}		-0.3 to V _{DD}	V	
Input Voltage	V _{IN1}	CX/TCLK, REF, FB, SENS terminals	-0.3 to V _{DD} +0.3	V	
Input Voltage	V _{IN2}	REQ, DATA, SCK, RSTb Terminals	-0.3 to V _{DDL} +0.3	V	
Switch Voltage	V _{SW}	SW terminal	+18.0	V	3
Power Dissipation	PD		T.B.D.	mW	4 5
Operating Temperature	T _{opr}		-40 to +85	°C	
Storage Temperature	T _{stg}		-55 to +125	°C	

NOTE1) All voltages are relative to V_{SS} = 0V reference.

NOTE2) Do not exceed the absolute maximum ratings, otherwise the stress may cause a permanent damage to the IC. It is also recommended that the IC be used in the range specified in the DC electrical characteristics, or the electrical stress may cause malfunctions and affect the reliability.

NOTE3) The switch voltage V_{SW} is the highest voltage in the system. This voltage must not exceed the absolute maximum rating.

$$V_{SW} = V_F(\text{LED}) \times N(\text{LED}) + V_F(\text{D1}) + V_{REF}$$

V_F(LED) :Forward Voltage of LED
 N(LED) :The Number of LEDs
 V_F(D1) :Forward Voltage of Diode D1

For instance,

when V_F(LED) = 3.6V, N(LED)=4pcs, V_F(D1)=0.3V, V_{REF}=0.6V(TYP), V_{SW} = 3.6V x 4 + 0.3V + 0.6V = 15.3V.

NOTE4) Mounted on the glass epoxy board (50mm x 50mm x 1.6mm)

NOTE5) Mounted on the board specified by EIA/JEDEC (2-layer FR-4, 76.2mm x 114.3mm x 1.6mm)

■ DC ELECTRICAL CHARACTERISTICS

$V_{DDL}=1.8$ to $3.6V$, $V_{DD}=3.0$ to $5.5V$, $T_a=-40$ to $85^{\circ}C$

PARAMETERS	SYMBOL	CONDITIONS	RATINGS			Unit	Note
			MIN.	TYP.	MAX.		
V_{DD} Power Supply	V_{DD}		3.0		5.5	V	
V_{DDL} Power Supply	V_{DDL}		1.8		3.6	V	
Output Current	I_{OUT}			60		mA	1
Reference Voltage	V_{REF}	$T_a=25^{\circ}C$ DC/DC Converter OFF	0.558	0.60	0.642	V	2
Operating Current	I_{OPR}	$f_{OSC}=350kHz$		1.0	1.4	mA	3
Standby Current	I_{STBY}				1	μA	4
V_{SO} Power Supply	V_{SO}		2.23	2.40	2.57	V	5
PWM REGISTER0 Selected Voltage	V_{D0}	SENS terminal, REV=0	0		$0.0055V_{SO}$	V	
PWM REGISTER1 Selected Voltage	V_{D1}	SENS terminal, REV=0	$0.015V_{SO}$		$0.0185V_{SO}$	V	
PWM REGISTER2 Selected Voltage	V_{D2}	SENS terminal, REV=0	$0.030V_{SO}$		$0.040V_{SO}$	V	
PWM REGISTER3 Selected Voltage	V_{D3}	SENS terminal, REV=0	$0.060V_{SO}$		$0.090V_{SO}$	V	
PWM REGISTER4 Selected Voltage	V_{D4}	SENS terminal, REV=0	$0.110V_{SO}$		$0.180V_{SO}$	V	
PWM REGISTER5 Selected Voltage	V_{D5}	SENS terminal, REV=0	$0.220V_{SO}$		$0.360V_{SO}$	V	
PWM REGISTER6 Selected Voltage	V_{D6}	SENS terminal, REV=0	$0.440V_{SO}$		$0.720V_{SO}$	V	
PWM REGISTER7 Selected Voltage	V_{D7}	SENS terminal, REV=0	$0.880V_{SO}$		V_{SO}	V	
Input "L" Level	V_{IL}	SCK, DATA, REQ, RSTb terminals	0		$0.2V_{DDL}$	V	
Input "H" Level	V_{IH}	SCK, DATA, REQ, RSTb terminals	$0.8V_{DDL}$		V_{DDL}	V	
Output "L" Level	V_{OL}	DATA terminals $V_{DDL}=1.8V$, $I_{OL}=0.4mA$			$0.2V_{DDL}$	V	
Output "H" Level	V_{OH}	DATA terminals $V_{DDL}=1.8V$, $I_{OH}= - 0.04mA$	$0.8V_{DDL}$			V	
Oscillation Frequency	f_{OSC}	$V_{DD}=3V$, $CX=82pF$	210	350	490	kHz	
Oscillation Duty	D_{OSC}	$V_{DD}=3V$, $CX=82pF$	77	82	87	%	6
Switch Current Limit	I_{LIMIT}	SW terminal, $V_{DD}=4.2V$ $V_{FB}>V_{REF}/2$, $T_a=25^{\circ}C$	610	720	825	mA	
Switch On Voltage	$V_{DS(on)}$	SW terminal, $V_{DD}=4.2V$ $I_{SW}=720mA$, $T_a=25^{\circ}C$		1	1.4	V	
Over Voltage Protection	V_{OVP}	V_{OUT} terminal		17.5		V	

NJU6052

NOTE1) Output Current Test Conditions

● TEST Command

	B7	B6	B5	B4	B3	B2	B1	B0
Command Data 1	0	1	0	0	0	0	0	0
Command Data 2	0	1	0	0	0	0	0	0
Duty Data	1	*	1	1	1	1	1	1

*: "Don't care"

● TEST Circuit

- V_{DD} :5V
- D1 :Schottky diode
- L1 :10uH
- C1 :4.7uF
- C2 :1uF
- R_{LED} :30Ω
- R_{LOAD} :750Ω
- R1 :100kΩ
- f_{osc} :350kHz / Duty 82%

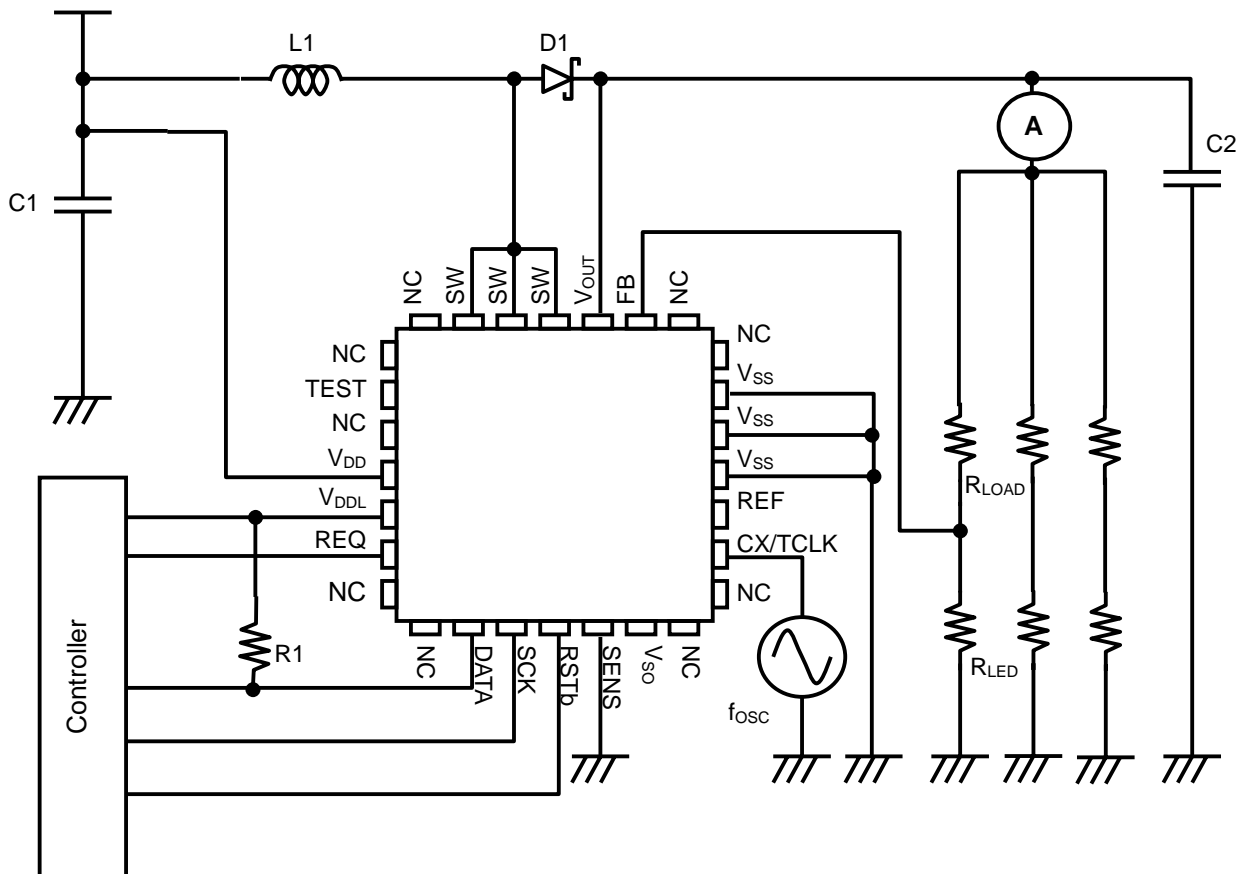

NOTE2) TEMPERATURE COMPENSATION

The reference voltage (V_{REF}) generator has temperature compensation, which suppresses the characteristic-degradation of LEDs at high temperatures. The V_{REF} is regulated to 0.6V typical in the temperature range up to 45°C, and gradually decreases as the ambient temperature rises in the range higher than 45°C.

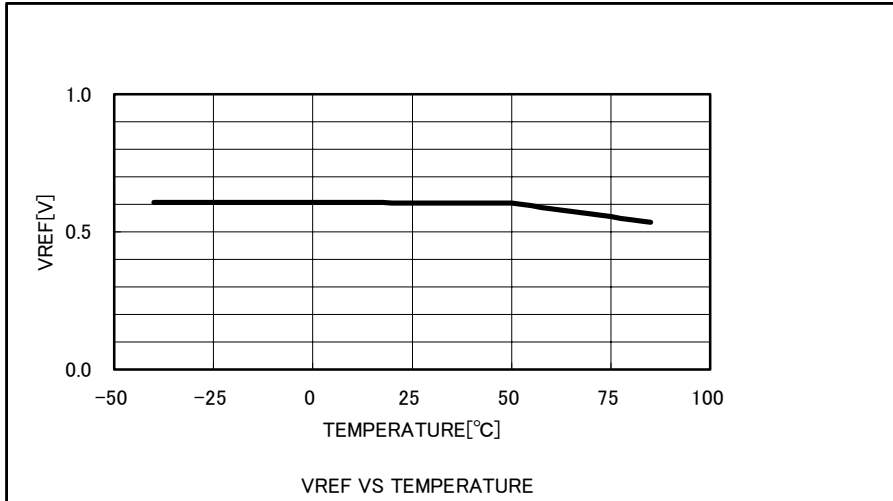

FIGURE 4 VREF vs. TEMPERATURE

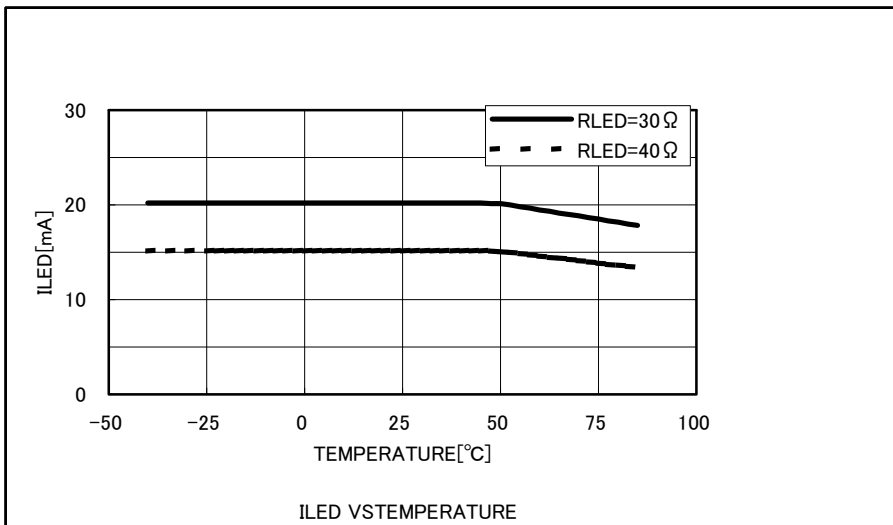

FIGURE 5 ILED vs. TEMPERATURE

NJU6052

NOTE3) Operating Current Test Conditions

● TEST Command

	B7	B6	B5	B4	B3	B2	B1	B0
Command Data 1	0	1	0	0	0	0	0	0
Command Data 2	0	1	0	0	0	0	0	0
Duty Data	1	*	1	1	1	1	1	1

*: "Don't care"

NOTE4) Standby Current

● TEST Command

	B7	B6	B5	B4	B3	B2	B1	B0
Command Data 1	0	*	*	*	*	1	*	*
Command Data 2	0	1	0	0	0	0	0	0

*: "Don't care"

● TEST Circuit (Operating Current, Standby Current)

- LED : $V_F=3.6V$, $I_{LED}=20mA$
- D1 : Schottky diode
- L1 : $10\mu H$
- C1 : $4.7\mu F$
- C2 : $1\mu F$
- R_{LED} : 30Ω
- R1 : $100K\Omega$
- f_{OSC} : $350kHz$ / Duty 82%

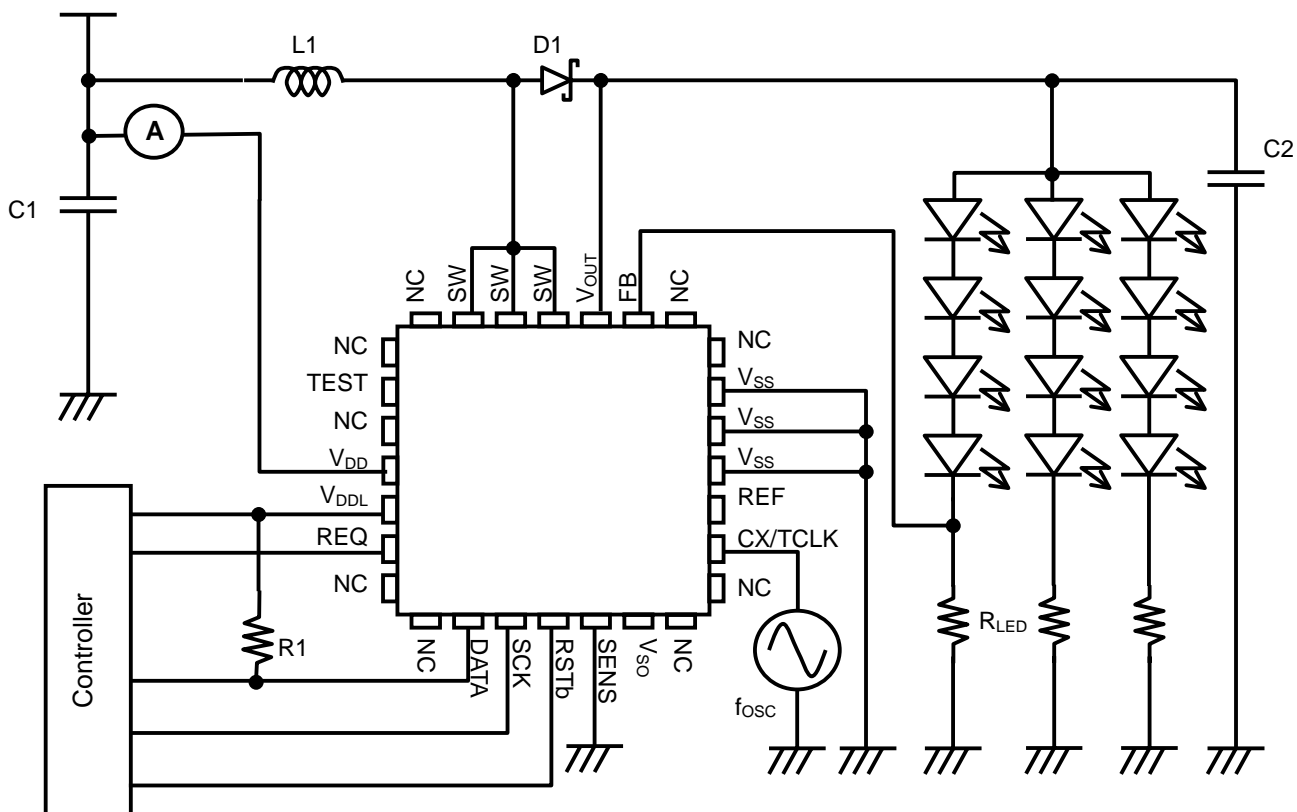

NOTE5) V_{SO} Power Supply Test Condition

● TEST Command

	B7	B6	B5	B4	B3	B2	B1	B0
Command Data 1	0	1	1	1	1	0	0	0
Command Data 2	0	1	0	0	1	0	0	0

● TEST Circuit

- LED : $V_F=3.6V, I_{LED}=20mA$
- D1 : Schottky diode
- L1 : $10\mu H$
- C1 : $4.7\mu F$
- C2 : $1\mu F$
- R_{LED} : 30Ω
- R1 : $100K\Omega$
- R2 : $1K\Omega$
- f_{osc} : $350kHz / \text{Duty } 82\%$

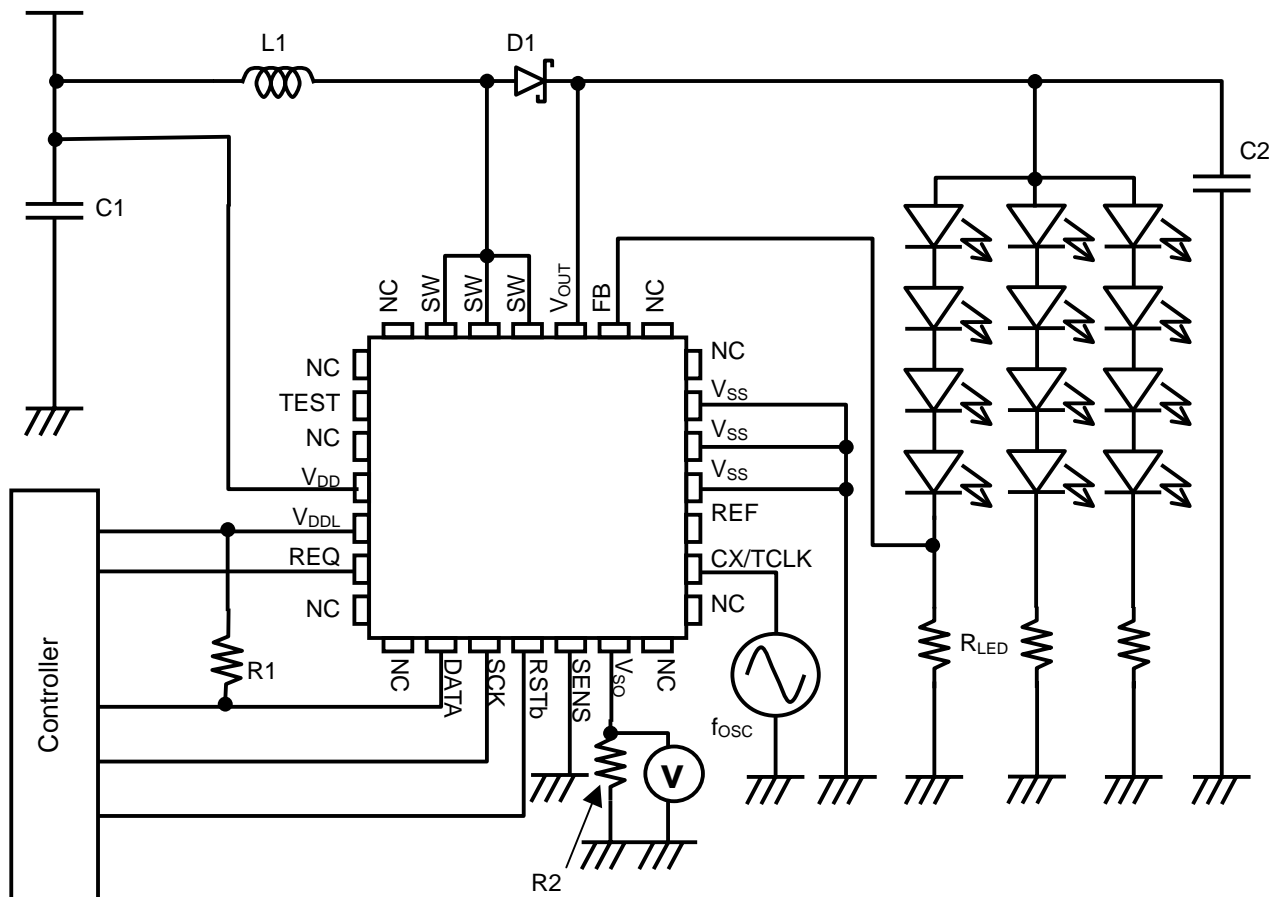

NOTE6) OSCILLATOR

The built-in oscillator incorporates a reference power supply, so its frequency is independent from the V_{DD} . The frequency is varied by the external capacitor CX, as shown below.

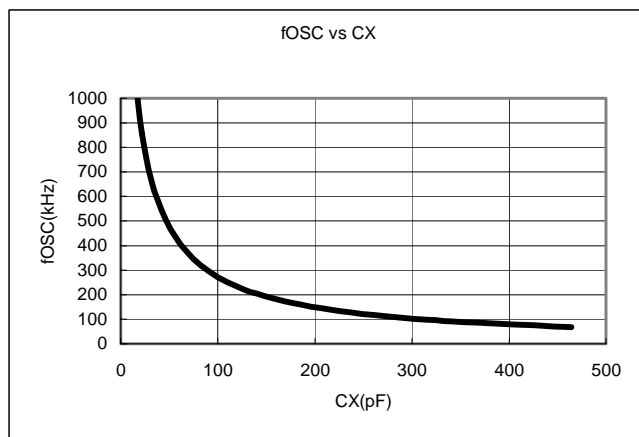

Figure 7 f_{osc} vs. CX
(Reference but not guaranteed)

AC ELECTRICAL CHARACTERISTICS

$V_{DDL}=1.8$ to $3.6V$, $V_{DD}=3.0$ to $5.5V$, $T_a=-40$ to $85^{\circ}C$

PARAMETERS	SYMBOL	RATINGS			UNIT
		MIN.	TYP.	MAX.	
SCK Clock Cycle	t_{SCCY}	1.0	-	-	us
SCK Clock Width	"H" Level	t_{WSCH}	-	-	ns
	"L" Level	t_{WSCL}	-	-	ns
REQ Hold Time	t_{REH}	800	-	-	ns
Data Set-Up Time	t_{DIS}	400	-	-	ns
Data Hold Time	t_{DIH}	400	-	-	ns
Output Data Delay Time $CL=20pF$	t_{DO}	-	-	200	ns
REQ Set-Up Time	t_{RES}	400	-	-	ns
REQ High Level Width	t_{WREH}	800	-	-	ns
REQ,SCK,DATA Rising Time	t_r	-	-	100	ns
REQ,SCK,DATA Falling Time	t_f	-	-	100	ns
RSTB Pulse Width	t_{RSL}	1.0	-	-	us

Serial Input Timing

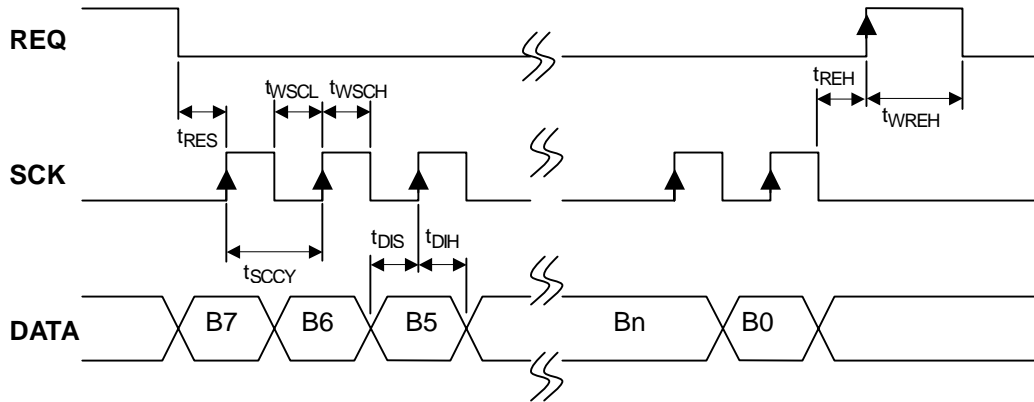

Serial Output Timing

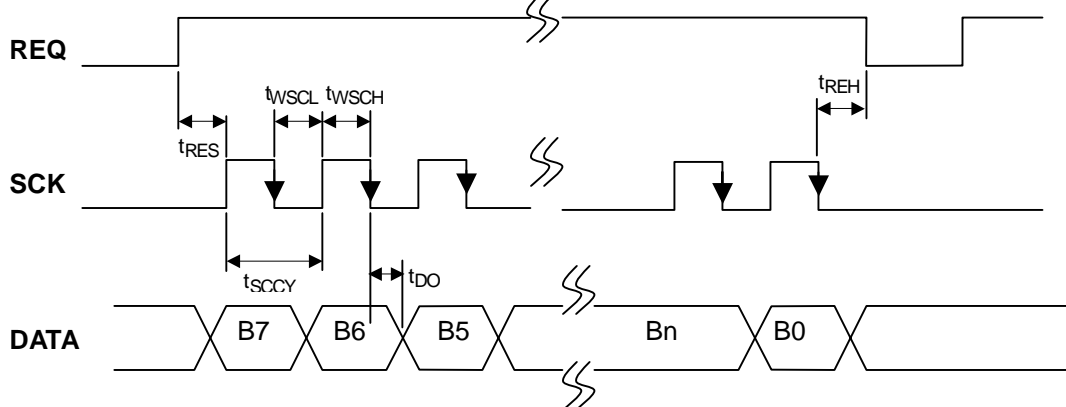

Reset Input Timing

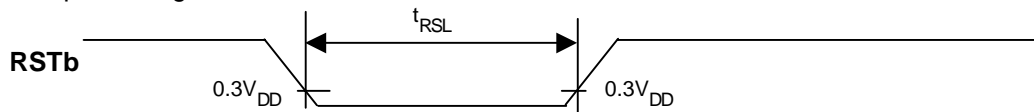

■ TYPICAL PERFORMANCE

1. Oscillation Frequency

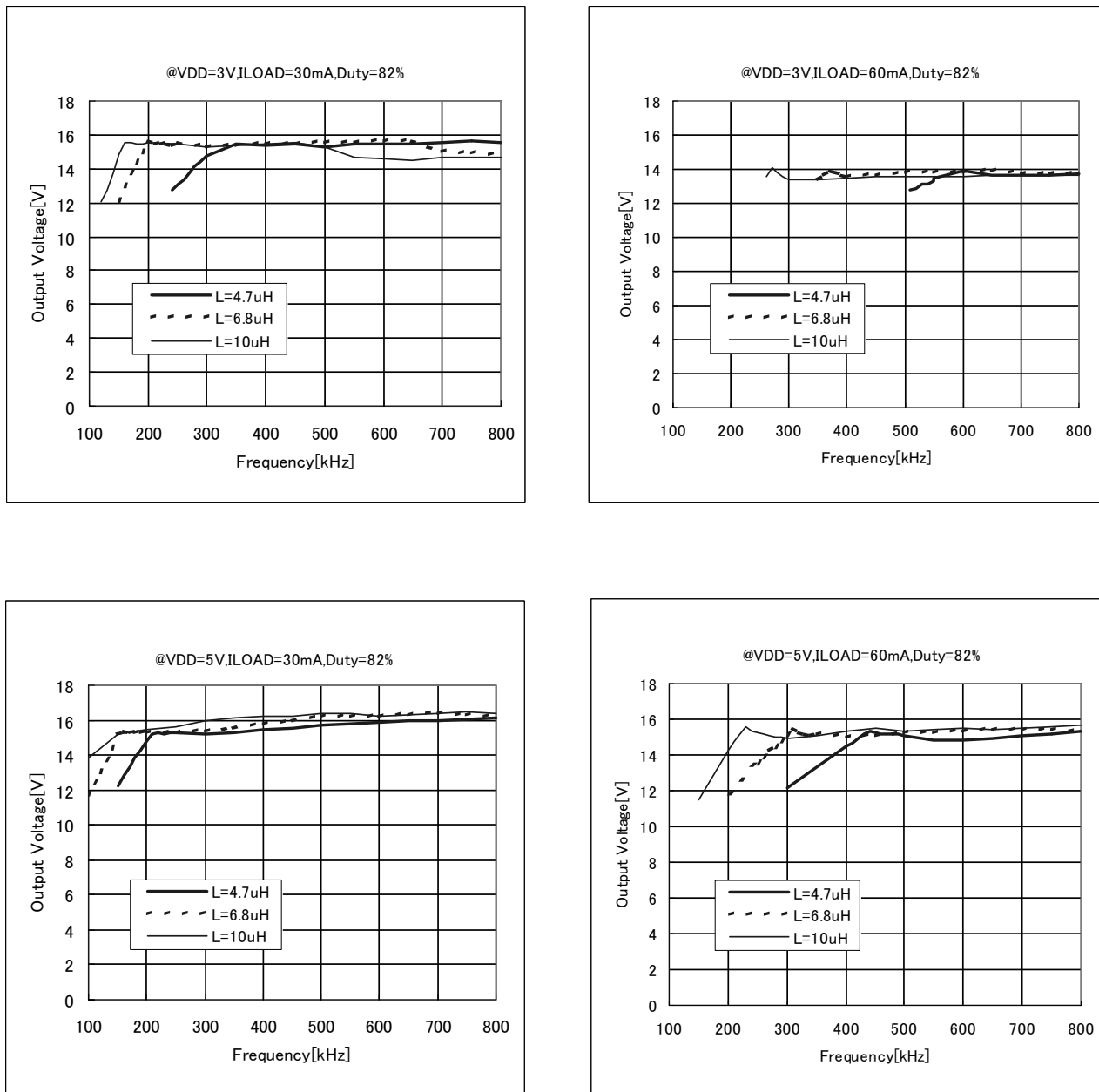

Figure 8 Output Voltage vs. Frequency

2. Load Current

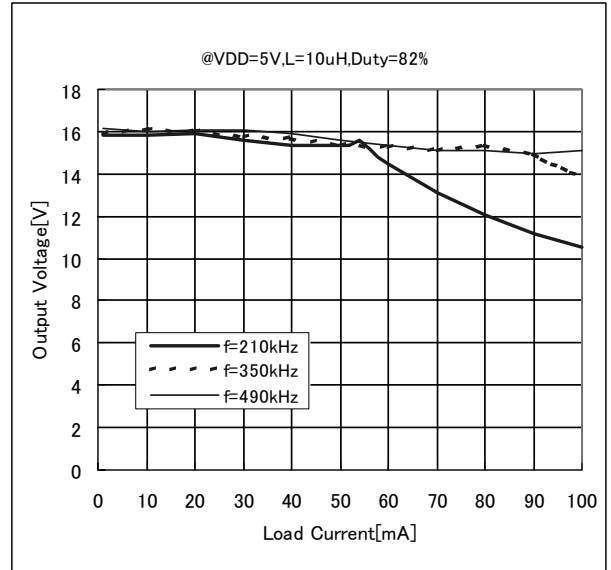
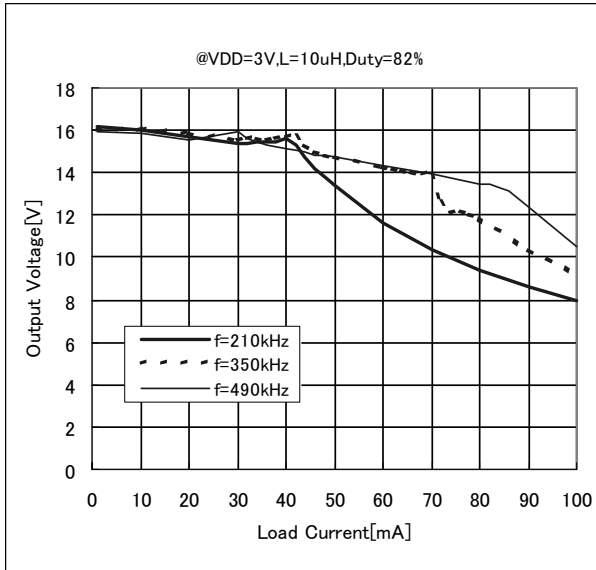

Figure 9 Output Voltage vs. Load Current

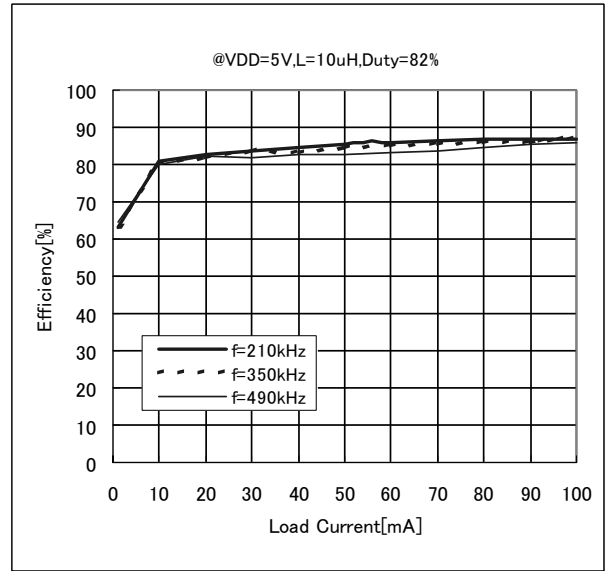
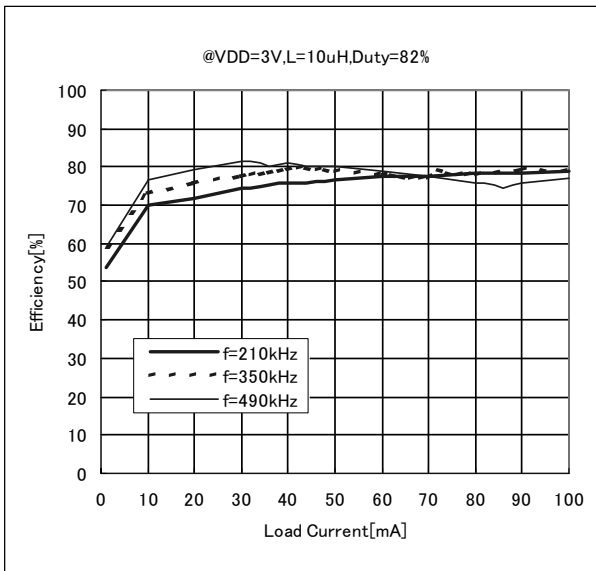

Figure 10 Efficiency vs. Load Current

3. Typical Performance TEST Circuit

● TEST Command

	B7	B6	B5	B4	B3	B2	B1	B0
Command Data 1	0	1	0	0	0	0	0	0
Command Data 2	0	1	0	0	0	0	0	0
Duty Data	1	*	1	1	1	1	1	1

* : "Don't care"

● TEST Circuit

- D1 : Schottky diode
- L1 : 10uH
- C1 : 4.7uF
- C2 : 1uF
- R_{LED} : 4.2kΩ
- R_{LOAD} : 100kΩ
- R1 : 100kΩ

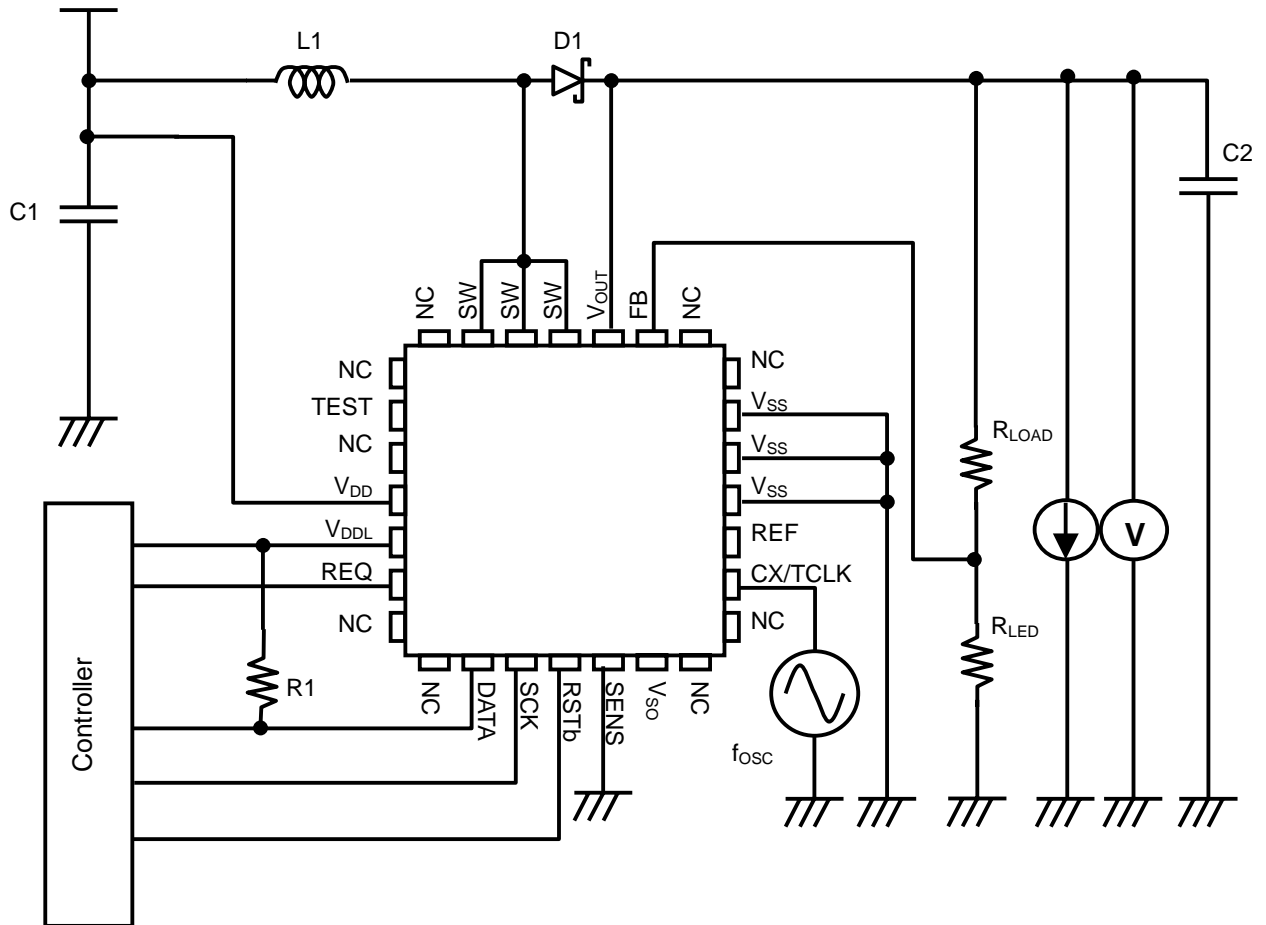

■ TYPICAL APPLICATION CIRCUIT

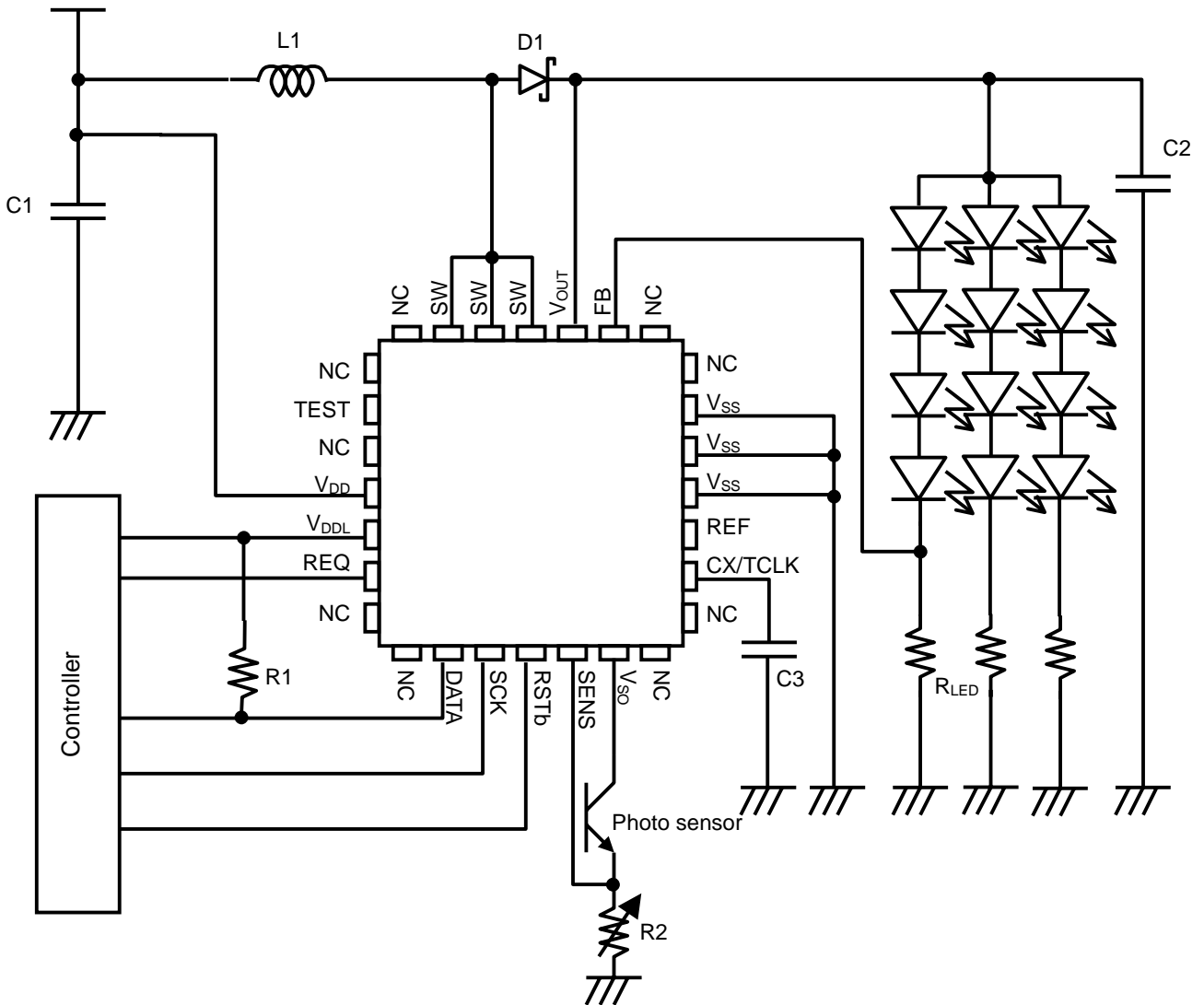

[CAUTION]
 The specifications on this databook are only given for information, without any guarantee as regards either mistakes or omissions. The application circuits in this databook are described only to show representative usages of the product and not intended for the guarantee or permission of any right including the industrial rights.